



DIW 01
DIW 03-DIW04

CORDLESS PHOTOCELL



INSTALLATION MANUAL

"IMPORTANT SAFETY INSTRUCTIONS FOR INSTALLATION"
"CAUTION: IMPROPER INSTALLATION MAY CAUSE
SERIOUS DAMAGE, FOLLOW ALL INSTALLATION INSTRUCTIONS
CAREFULLY"
"THIS MANUAL IS ONLY FOR PROFESSIONAL INSTALLERS
OR QUALIFIED PERSONS"

Legend of symbols



This symbol indicates sections to be read with particular care.



This symbol indicates sections concerning safety



This symbol indicates notes to communicate to users.

Reference Standards

with the following standards:

EN 12978, UNI EN 954-1, CEI EN 60335-1, UNI EN 12453.

Description of devices

Designed and manufactured by CAME CANCELLI AUTOMATICI S.p.A. in compliance with the safety regulations in force.S.p.A.

DIW01

Protection device Made up of two units:

-12/24v AC/DC Infrared receiver.

1 led to signal that battery is run down (when the led on the receiver flashes, this means that the batteries' charge will completely run down in about a month)

-Battery powered infrared transmitter (works on four 1.5V AAA batteries)

DIW03

- Infrared repeater, made up of a central transmitter photodiode and two lateral receiver photodiodes, with dip switches for selecting receiving side.

Battery powered (works on four 1.5V AAA batteries)

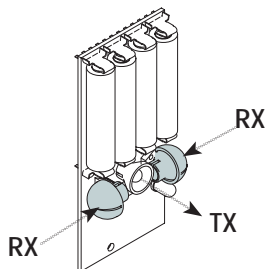

DIW04

- Infrared repeater, made up of a central photodiode receiver and two lateral, transmitting photodiodes, with dip switches for selecting the emitting side.

Battery powered (works on four 1.5V AAA batteries)

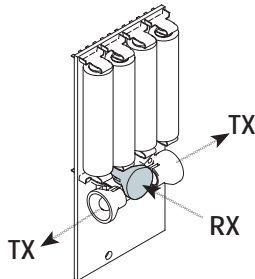

Technical data

DIW01 (TX)

Power supply: (4 1.5V AAA batteries)

Draw: 70 μ A

Degree of protection: IP 54

Material: PC-ABS UL94V0 / Policarbonato / Marpram mar TPA1 65 NT

Working temperature:



DIW 01 (RX)

Power supply: 12/ 24 V.A.C. - D.C.

Draw: 48 mA

Degree of protection: IP 54

Material: PC-ABS UL94V0 / Policarbonato / Marpram mar TPA1 65 NT

Working temperature:



Ripetitore DIW03

Power supply: (4 1.5V AAA batteries)

Draw: 70 μ A

Degree of protection: IP 54

Material: PC-ABS UL94V0 / Policarbonato / Marpram mar TPA1 65 NT

Working temperature:



Ripetitore DIW04

Power supply: (4 1.5V AAA batteries)

Draw: 70 μ A

Degree of protection: IP 54

Material: PC-ABS UL94V0 / Policarbonato / Marpram mar TPA1 65 NT

Working temperature:



Dimensions and holes pitch

Receiver/Transmitter/Repeater

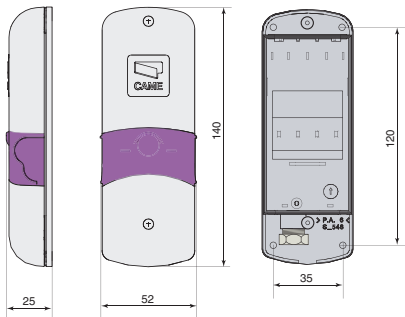

Installation



Before installing you must:

- Make sure that the line voltage is disconnected.
- See that the point, to which the equipment will be mounted, is in an area protected from any impacts, that the mounting surface is solid, and that the mounting on to the surface is carried out with the proper hardware (bolts, pins, etc).
- Provide for proper electrical cable conduits making sure that they are free from any mechanical damage.

Description/Electrical connections and DIP switch functions

DIW01 (TX)

- 1-Battery housing (four 1.5V AAA batteries)
- 2-Infrared led

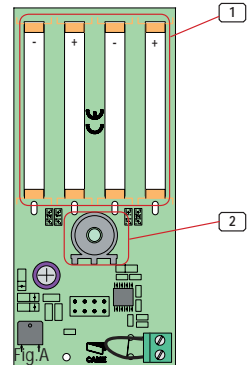
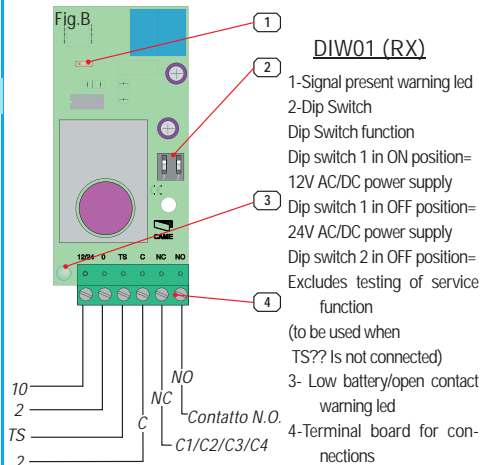
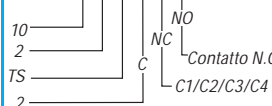

Fig.B



DIW01 (RX)

- 1-Signal present warning led
- 2-Dip Switch
Dip Switch function
Dip switch 1 in ON position= 12V AC/DC power supply
Dip switch 1 in OFF position= 24V AC/DC power supply
Dip switch 2 in OFF position= Excludes testing of service function
(to be used when TSS?? Is not connected)
- 3- Low battery/open contact warning led
- 4-Terminal board for connections



DIW03 Repeater

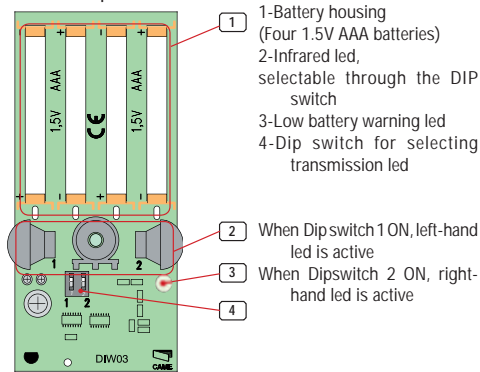

DIW04 Repeater

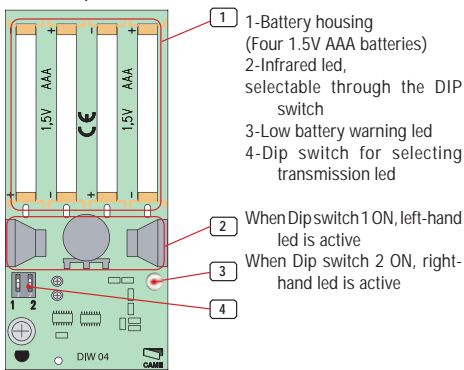

Example of a standard installation and relative Dip Switch configuration

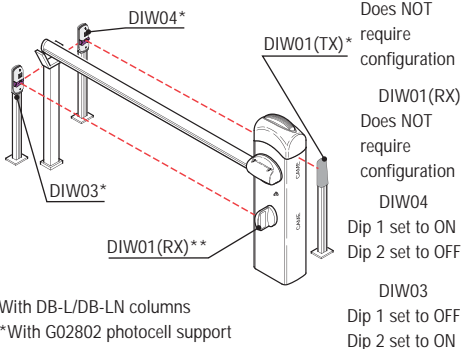

*With DB-L/DB-LN columns

**With G02802 photocell support

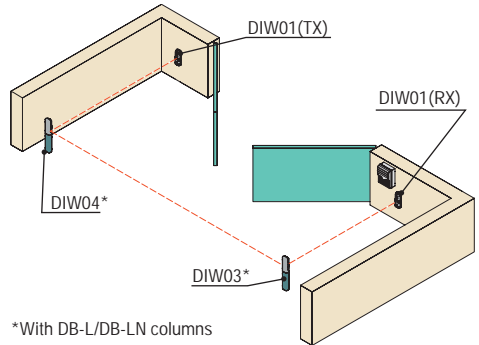

*With DB-L/DB-LN columns

DIW01(TX)	DIW01(RX)	DIW04	DIW03
Does NOT require configuration	Does NOT require configuration	Dip 1 set to ON Dip 2 set to OFF	Dip 1 set to OFF Dip 2 set to ON

Note: When using DIW01, DIW03 and DIW04, as explained in the two preceding configurations, remember to remove the bridge on DIW01 (TX)

Assembly

Make sure that the distance between the two photocells is not greater than 10 metres, and that they are perfectly aligned, before installing. Now mount the bases of the photocells, using proper screws that suit the attachment structure (max. \varnothing 6 mm). Insert the batteries (you will need four 1.5V AAAs) into the transmitter and the repeaters making sure the polarity matches that shown on the card. Set the leds to (ON/OFF) depending on the make up of the system. Fasten the transmitters/repeater using the screws provided.

Carry out the connections for the receiver/s as shown in fig. B.

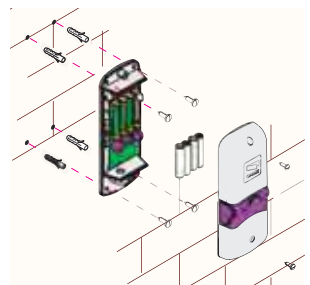

Connecting DIW01 with DIR/DOC

DIW01 with DIR

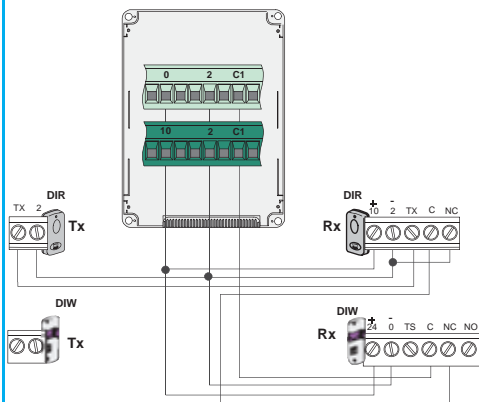

DIW01 with DOC

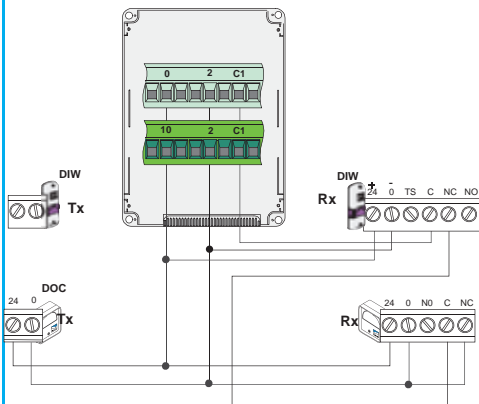

Problems

- The led on the receiver is flashing: the transmitter battery is run down
- The led on the receiver stays on: signal is interrupted due to transmitter malfunction.

Demolition and disposal

Product disposal

Our products are made up of various types of materials. Most of them (aluminium, plastics, iron, electrical wires, etc.) may be disposed of in normal garbage collection bins and can be recycled by disposing of in specific recyclable material collection bins and disposal in authorized centres.

Other components (electrical boards, remote control batteries, etc.), however, may contain polluting substances. They should therefore be removed and given to qualified service companies for proper disposal.

Prior to disposal, it is always advisable to check specific regulations in force in the place of disposal.

PLEASE DISPOSE OF PROPERLY!

Manufacturer's declaration

CE Declaration of conformity

la CAME Cancelli Automatici S.p.A.

via Martiri della Libertà, 15

31030 Dosson di Casier - Treviso - ITALYtel

(+39) 0422 4940 - fax (+39) 0422 4941

internet: www.came.it - e-mail: info@came.it

Declare under their own responsibility that the following products for gate and garage door automation called:

DIW01- DIW03-DIW04

Are compliant with essential requirements and with pertinent regulations established by the following directives and to the applicable parts of the standards listed below:

Electromagnetic compatibility directive 89/336/EEC - 92/31/EEC

Electrical equipment designed for use within certain voltage

limits directive 73/23/EEC - 93/68/EEC

Machinery directive 98/37/EC

EN 61000-6-2

EN 61000-6-3

EN 12978

EN 60529

EN 954-1

L'amministratore delegato
Sig. Andrea Menuzzo

119RT88 v2



CAME CANCELLI AUTOMATICI S.p.A.

VIA MARTIRI DELLA LIBERTÀ 15

31030 DOSSON DI CASIER - TV - ITALY

www.came.it

Per assistenza e informazioni tecniche

